

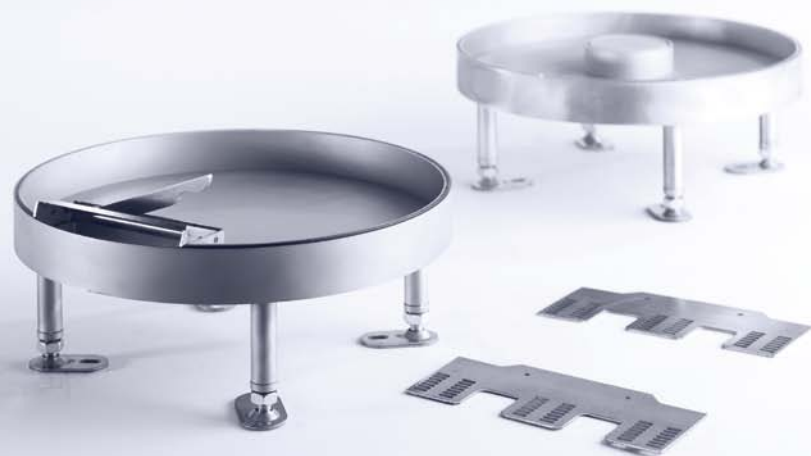

**Heavy-duty cartridge units
made of stainless steel**
Assembly instruction

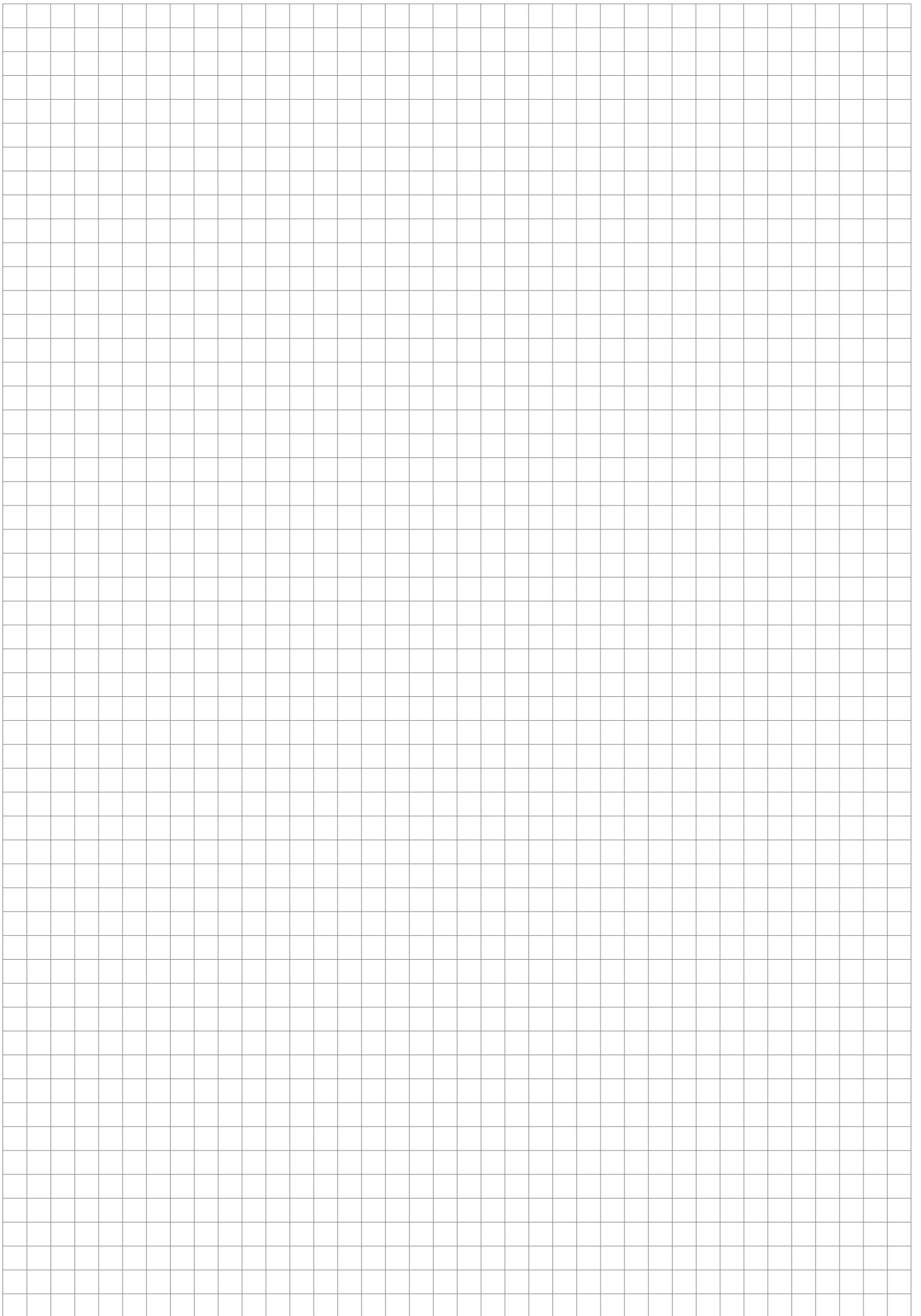



Heavy-duty cartridge units made of stainless steel

Assembly instruction

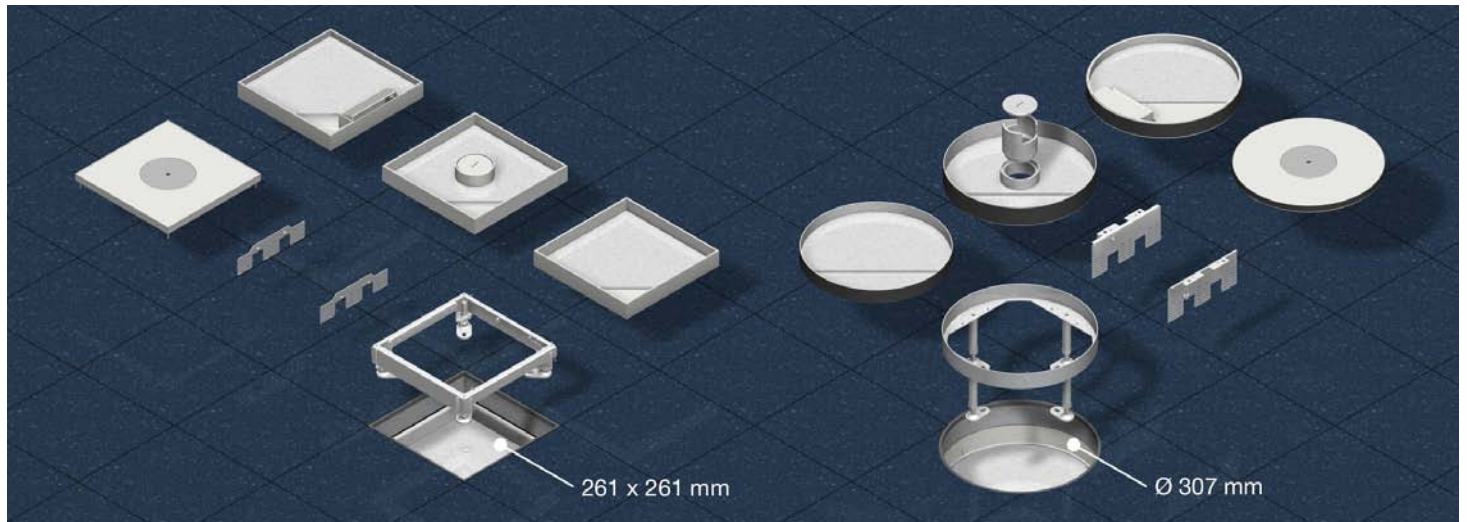

Stainless steel installation cartridge with levelling device, round or quadrangular, as dummy-, cable-outlet- or tube outlet cartridge with steel inlay for working loads up to 10 or 20 kN.

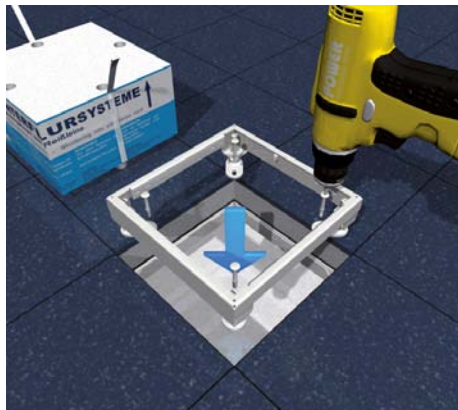

1 | Levelling device

Remove shuttering unit and insert levelling device into the floor opening. Fasten the four levelling bases to the slab ceiling with drilling screws.

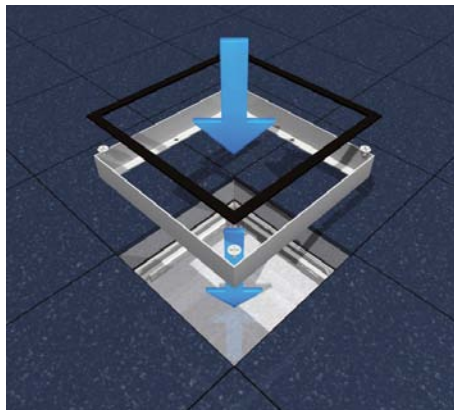

2 | Stainless steel frame

Put the stainless steel frame on the levelling device. Tighten the four screws. Lay in the rubber seal.

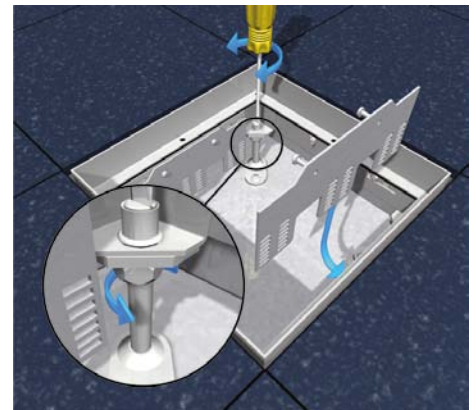

3 | Levelling to floor

Adjust installation frame flush to the height of the floor construction with the four levelling bases. Counter the levelling bases against the frame with hexagonal nuts.

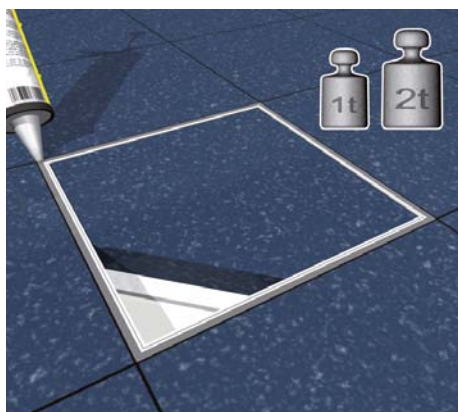

4 | Dummy cartridge 10/20 kN

Put cartridge with integrated steel inlay into the frame, seal expansion joint. For loads from 10 kN up, the covering thickness must be at least 16 mm. For loads from 20 kN up, the covering thickness must be at least 24 mm.

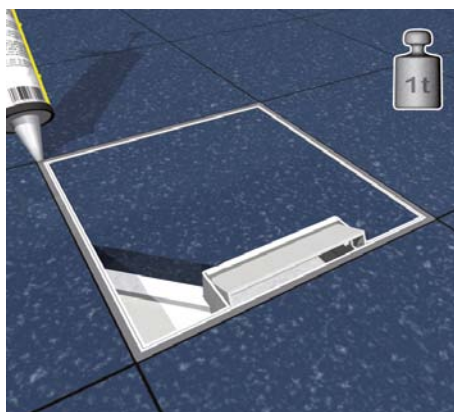

5 | Cable outlet cartridge 10 kN

Put cartridge with integrated steel inlay into the frame, seal expansion joint. For covering thickness from 16 mm up.

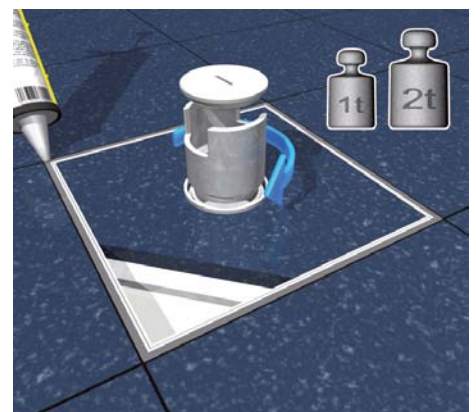

6 | Tube outlet cartridge 10/20 kN

Put cartridge with integrated steel inlay and tube assembly set into the frame. Replenish the system with the tube. Seal expansion joint. For loads from 10 kN up, the covering thickness must be at least 16 mm. For loads from 20 kN up, the covering thickness must be at least 24 mm. Alternatively, a flat cartridge can be used for working loads up to 20 kN.

