



Cable clamps

Cable clamps

A03-A19



A

Numeric index

Cable clamps

A

AC Cable clamp for fastening to C-profiles [A03](#)
ACF-E Cable clamp for fastening to C-profiles [A11](#)
AC-IW Cable clamp with additional insulating vat [A05](#)

B

B Cable clamp for fastening to profile rails [A08](#)

H

H Cable clamp for fastening to C-profiles [A06](#)
HB Cable clamp for fastening to profile rails [A09](#)
HB-IW Cable clamp with additional insulating vat [A10](#)
H-IW Cable clamp with additional insulating vat [A07](#)
HK 100 cable hook, Ø 100 mm [A18](#)
HK 30-70 cable hook [A17](#)

K

KH cable support [A19](#)

R

RU Cable clamp for fastening to round sections [A17](#)

S

S Cable clamp for fastening to angle profiles [A12](#)
S-IW Cable clamp with additional insulating vat [A14](#)

U

U Cable clamp for fastening to flat sections [A15](#)
U-IW Cable clamp with additional insulating vat [A16](#)

W

W Cable clamp for wall fastening [A18](#)

Cable clamps

AC Cable clamp for fastening to C-profiles

Articles with a diameter of 12-56mm are also available in stainless steel finish, material No. 1.4571 / 1.4404 (V4A).
For an application example, see the chapter assembly.

article number	D mm	H _{max} mm	M Nm	number of cables	G kg/100
Z					
12 AC	8-12	41	2,0	1	2,7
16 AC	12-16	46	2,0	1	3,1
20 AC	16-20	50	2,0	1	3,5
24 AC	20-24	54	2,0	1	3,7
28 AC	24-28	58	2,0	1	4,2
32 AC	28-32	63	2,0	1	6,4
36 AC	32-36	67	2,0	1	6,7
40 AC	36-40	71	2,0	1	7,5
44 AC	40-44	81	4,0	1	9,6
48 AC	44-48	85	4,0	1	9,8
52 AC	48-52	90	4,0	1	10,7
56 AC	52-56	94	4,0	1	11,5
60 AC	56-60	98	4,0	1	15,1
64 AC	60-64	102	4,0	1	15,9
70 AC	64-70	109	4,0	1	16,9
76 AC	70-76	113	4,0	1	23,3
82 AC	76-82	119	4,0	1	25,8
88 AC	82-88	125	4,0	1	27,3
94 AC	88-94	131	4,0	1	29,6
100 AC	94-100	137	4,0	1	32,0
110 AC	100-110	157	4,0	1	35,0
120 AC	110-120	167	4,0	1	37,4
150 AC	145-150	203	6,0	1	104,6
175 AC	170-175	228	6,0	1	130,3
12/2 AC	8-12	58	2,0	2	3,5
16/2 AC	12-16	67	2,0	2	4,0
20/2 AC	16-20	75	2,0	2	4,6
24/2 AC	20-24	84	2,0	2	5,0
28/2 AC	24-28	92	2,0	2	5,7
32/2 AC	28-32	101	2,0	2	8,9
36/2 AC	32-36	109	2,0	2	9,9
40/2 AC	36-40	117	2,0	2	11,4
44/2 AC	40-44	127	4,0	2	13,1
48/2 AC	44-48	135	4,0	2	14,2
52/2 AC	48-52	144	4,0	2	15,7
56/2 AC	52-56	152	4,0	2	15,9
12/3 AC	8-12	71	2,0	3	4,3
16/3 AC	12-16	85	2,0	3	5,1
20/3 AC	16-20	97	2,0	3	5,9
24/3 AC	20-24	110	2,0	3	6,7
28/3 AC	24-28	122	2,0	3	7,4

accessories optional:

A 41	C-rail, not perforated, 41x41 mm	(catalogue Cable trays)
A 2	C-rail, not perforated, 50x31 mm	(catalogue Cable trays)
A 4	C-rail, not perforated, 48x26 mm	(catalogue Cable trays)
A 9	C-rail, not perforated, 40x25 mm	(catalogue Cable trays)
A 8	C-rail, not perforated, 40x22 mm	(catalogue Cable trays)
A 7	C-rail, not perforated, 40x22 mm	(catalogue Cable trays)

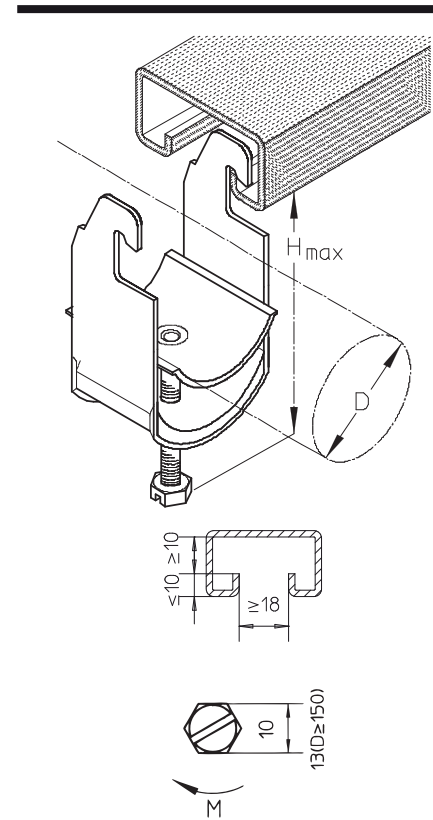

Cable clamps

AC Cable clamp for fastening to C-profiles

Articles with a diameter of 12-56mm are also available in stainless steel finish, material No. 1.4571 / 1.4404 (V4A).
For an application example, see the chapter assembly.

article number	D mm	H _{max} mm	M Nm	number of cables	G kg/100
E					
12 AC-E	8-12	41	2,0	1	2,6
16 AC-E	12-16	46	2,0	1	2,9
20 AC-E	16-20	50	2,0	1	3,2
24 AC-E	20-24	54	2,0	1	3,6
28 AC-E	24-28	58	2,0	1	4,1
32 AC-E	28-32	63	2,0	1	4,8
36 AC-E	32-36	67	2,0	1	5,8
40 AC-E	36-40	71	2,0	1	6,6
44 AC-E	40-44	81	4,0	1	8,6
48 AC-E	44-48	85	4,0	1	9,1
52 AC-E	48-52	90	4,0	1	9,8
56 AC-E	52-56	94	4,0	1	10,8
12/2 AC-E	8-12	58	2,0	2	3,4
16/2 AC-E	12-16	67	2,0	2	3,8
20/2 AC-E	16-20	75	2,0	2	4,3
24/2 AC-E	20-24	84	2,0	2	5,0
28/2 AC-E	24-28	92	2,0	2	5,4
32/2 AC-E	28-32	101	2,0	2	7,3
36/2 AC-E	32-36	109	2,0	2	8,1
40/2 AC-E	36-40	117	2,0	2	9,7
44/2 AC-E	40-44	127	4,0	2	11,7
48/2 AC-E	44-48	135	4,0	2	12,9
52/2 AC-E	48-52	144	4,0	2	14,0
56/2 AC-E	52-56	152	4,0	2	14,9

AL					
12 AC-AL	8-12	41	1,5	1	1,2
16 AC-AL	12-16	46	1,5	1	1,4
20 AC-AL	16-20	50	1,5	1	1,6
24 AC-AL	20-24	54	1,5	1	1,8
28 AC-AL	24-28	58	1,5	1	2,0
32 AC-AL	28-32	63	1,5	1	3,3
36 AC-AL	32-36	67	1,5	1	3,6
40 AC-AL	36-40	71	1,5	1	4,0
44 AC-AL	40-44	81	3,0	1	4,3
48 AC-AL	44-48	85	3,0	1	4,6
52 AC-AL	48-52	90	3,0	1	5,3
56 AC-AL	52-56	94	3,0	1	5,6

accessories optional:

- A 41** C-rail, not perforated, 41x41 mm (catalogue Cable trays)
- A 2** C-rail, not perforated, 50x31 mm (catalogue Cable trays)
- A 4** C-rail, not perforated, 48x26 mm (catalogue Cable trays)
- A 9** C-rail, not perforated, 40x25 mm (catalogue Cable trays)
- A 8** C-rail, not perforated, 40x22 mm (catalogue Cable trays)
- A 7** C-rail, not perforated, 40x22 mm (catalogue Cable trays)

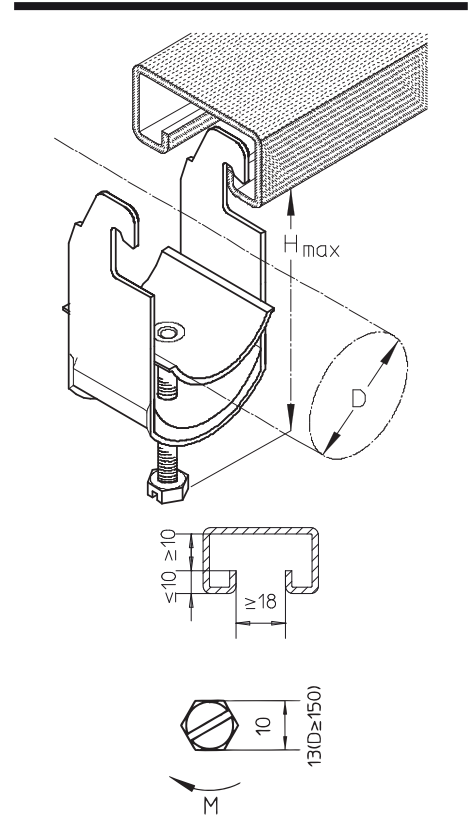

Cable clamps

AC-IW Cable clamp with additional insulating vat

article number	D mm	H _{max} mm	M Nm	number of cables	G kg/100
Z					
12 AC-IW	8-12	42,5	2	1	2,8
16 AC-IW	12-16	47,5	2	1	3,2
20 AC-IW	16-20	51,5	2	1	3,6
24 AC-IW	20-24	55,7	2	1	4,2
28 AC-IW	24-28	59,7	2	1	4,5
32 AC-IW	28-32	65,0	2	1	7,1
36 AC-IW	32-36	69,0	2	1	7,5
40 AC-IW	36-40	73,0	2	1	8,2
44 AC-IW	40-44	83,0	4	1	10,2
48 AC-IW	44-48	87,0	4	1	10,6
52 AC-IW	48-52	92,5	4	1	11,6
56 AC-IW	52-56	96,5	4	1	12,2
60 AC-IW	56-60	100,5	4	1	15,9
64 AC-IW	60-64	104,5	4	1	17,5
70 AC-IW	64-70	111,5	4	1	18,6

accessories optional:

A 41	C-rail, not perforated, 41x41 mm	(catalogue Cable trays)
A 2	C-rail, not perforated, 50x31 mm	(catalogue Cable trays)
A 4	C-rail, not perforated, 48x26 mm	(catalogue Cable trays)
A 9	C-rail, not perforated, 40x25 mm	(catalogue Cable trays)
A 8	C-rail, not perforated, 40x22 mm	(catalogue Cable trays)
A 7	C-rail, not perforated, 40x22 mm	(catalogue Cable trays)

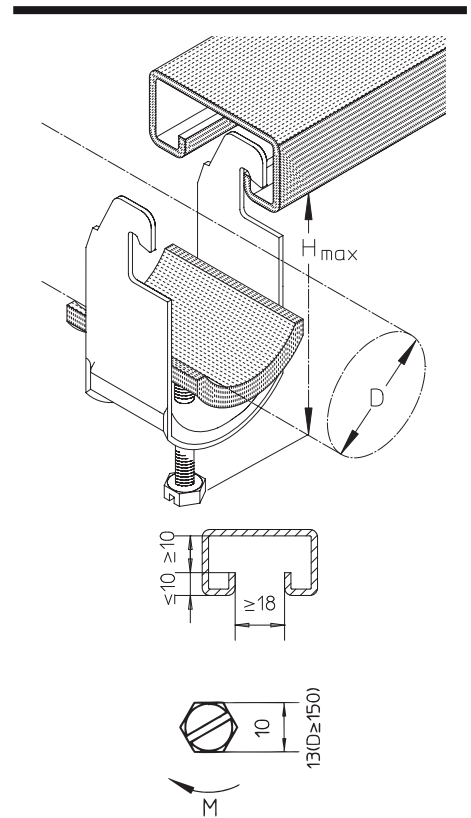

Cable clamps

H Cable clamp for fastening to C-profiles

Articles with a diameter of 12-56mm are also available in stainless steel finish, material No. 1.4571 / 1.4404 (V4A).

article number	D mm	H _{max} mm	M Nm	number of cables	G kg/100
Z					
12 H	8-12	41	2,0	1	2,7
16 H	12-16	46	2,0	1	3,2
20 H	16-20	50	2,0	1	3,6
24 H	20-24	54	2,0	1	3,9
28 H	24-28	58	2,0	1	4,4
32 H	28-32	63	2,0	1	6,3
36 H	32-36	67	2,0	1	7,0
40 H	36-40	71	2,0	1	7,5
44 H	40-44	81	4,0	1	9,8
48 H	44-48	85	4,0	1	10,2
52 H	48-52	90	4,0	1	10,6
56 H	52-56	94	4,0	1	11,3
60 H	56-60	98	4,0	1	15,8
64 H	60-64	102	4,0	1	16,5
70 H	64-70	109	4,0	1	17,1
12/2 H	8-12	58	2,0	2	3,5
16/2 H	12-16	67	2,0	2	4,0
20/2 H	16-20	75	2,0	2	4,8
24/2 H	20-24	84	2,0	2	5,3
28/2 H	24-28	92	2,0	2	6,0
32/2 H	28-32	101	2,0	2	8,9
36/2 H	32-36	109	2,0	2	9,6
40/2 H	36-40	117	2,0	2	10,8
44/2 H	40-44	127	4,0	2	13,3
48/2 H	44-48	135	4,0	2	13,9
52/2 H	48-52	144	4,0	2	15,2
56/2 H	52-56	152	4,0	2	16,2
12/3 H	8-12	71	2,0	3	4,3
28/3 H	24-28	122	2,0	3	7,4

E					
12 H-E	8-12	41	2,0	1	2,7
16 H-E	12-16	46	2,0	1	3,2
20 H-E	16-20	50	2,0	1	3,6
24 H-E	20-24	54	2,0	1	3,9
28 H-E	24-28	58	2,0	1	4,4
32 H-E	28-32	63	2,0	1	5,4
36 H-E	32-36	67	2,0	1	6,1
40 H-E	36-40	71	2,0	1	6,5
44 H-E	40-44	81	4,0	1	8,7
48 H-E	44-48	85	4,0	1	9,0
52 H-E	48-52	90	4,0	1	9,3
56 H-E	52-56	94	4,0	1	9,9
12/2 H-E	8-12	58	2,0	2	3,5
16/2 H-E	12-16	67	2,0	2	4,0
20/2 H-E	16-20	75	2,0	2	4,8
24/2 H-E	20-24	84	2,0	2	5,3
28/2 H-E	24-28	92	2,0	2	6,0
32/2 H-E	28-32	101	2,0	2	7,7

accessories optional:

B 7 profile rail, not perforated, 30x15 mm (catalogue Cable trays)

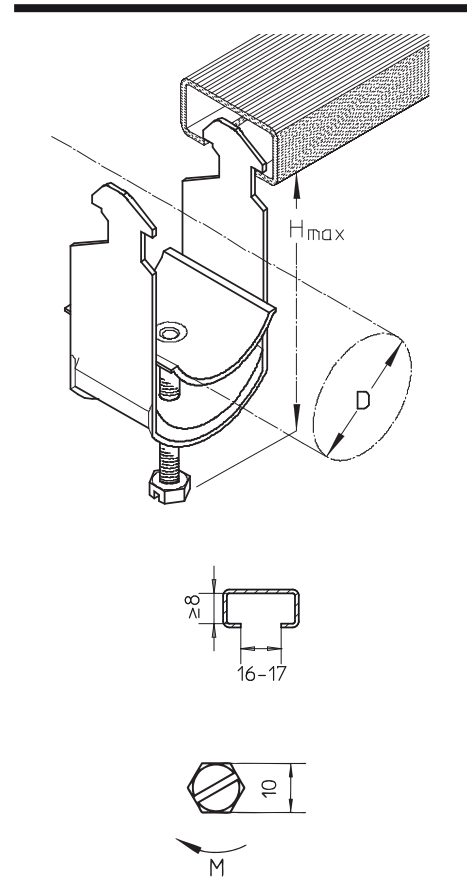

Cable clamps

H Cable clamp for fastening to C-profiles

Articles with a diameter of 12-56mm are also available in stainless steel finish, material No. 1.4571 / 1.4404 (V4A).

article number	D mm	H _{max} mm	M Nm	number of cables	G kg/100
AL					
12 H-AL	8-12	41	1,5	1	2,1
16 H-AL	12-16	46	1,5	1	2,5
20 H-AL	16-20	50	1,5	1	2,9
24 H-AL	20-24	54	1,5	1	3,3
28 H-AL	24-28	58	1,5	1	3,6
32 H-AL	28-32	63	1,5	1	5,0
36 H-AL	32-36	67	1,5	1	5,5
40 H-AL	36-40	71	1,5	1	5,9
44 H-AL	40-44	81	3,0	1	7,6
48 H-AL	44-48	85	3,0	1	8,3
52 H-AL	48-52	90	3,0	1	10,2
56 H-AL	52-56	94	3,0	1	10,6

accessories optional:

B 7 profile rail, not perforated, 30x15 mm (catalogue Cable trays)

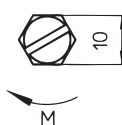
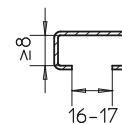
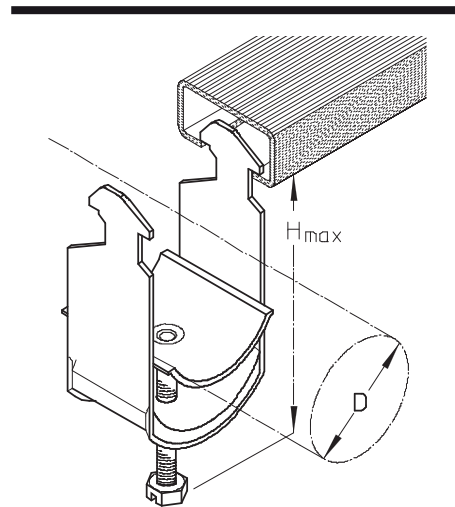

H-IW Cable clamp with additional insulating vat

article number	D mm	H _{max} mm	M Nm	number of cables	G kg/100
Z					
12 H-IW	8-12	42,5	2	1	2,7
16 H-IW	12-16	47,5	2	1	3,1
20 H-IW	16-20	51,5	2	1	3,5
24 H-IW	20-24	55,7	2	1	3,9
28 H-IW	24-28	59,7	2	1	4,3
32 H-IW	28-32	65,0	2	1	6,6
36 H-IW	32-36	69,0	2	1	7,1
40 H-IW	36-40	73,0	2	1	7,8
44 H-IW	40-44	83,0	4	1	9,5
48 H-IW	44-48	87,0	4	1	10,1
52 H-IW	48-52	92,5	4	1	11,6
56 H-IW	52-56	96,5	4	1	12,2
60 H-IW	56-60	100,5	4	1	15,4
64 H-IW	60-64	104,5	4	1	16,6
70 H-IW	64-70	111,5	4	1	16,9

accessories optional:

B 7 profile rail, not perforated, 30x15 mm (catalogue Cable trays)

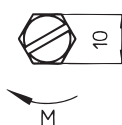
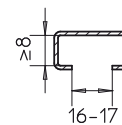
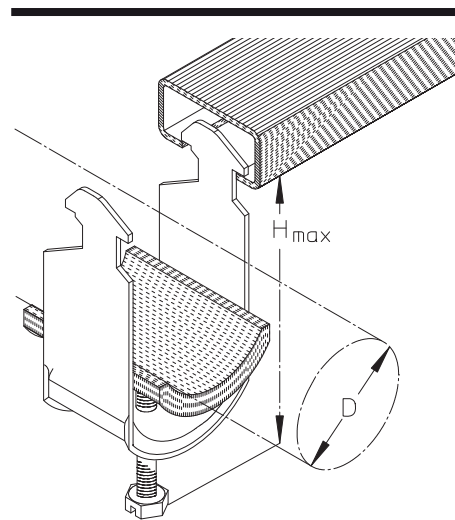

Cable clamps

B Cable clamp for fastening to profile rails

article number	D mm	H _{max} mm	M Nm	number of cables	G kg/100
Z					
12 B	8-12	41	2	1	2,5
16 B	12-16	46	2	1	2,8
20 B	16-20	50	2	1	3,2
24 B	20-24	54	2	1	3,5
28 B	24-28	58	2	1	3,9
32 B	28-32	63	2	1	6,1
36 B	32-36	67	2	1	6,6
40 B	36-40	71	2	1	7,9
44 B	40-44	81	4	1	9,2
48 B	44-48	85	4	1	9,7
52 B	48-52	90	4	1	10,7
56 B	52-56	94	4	1	11,4
60 B	56-60	98	4	1	14,1
64 B	60-64	102	4	1	15,0
70 B	64-70	109	4	1	16,8
12/2 B	8-12	58	2	2	3,3
16/2 B	12-16	67	2	2	4,0
20/2 B	16-20	75	2	2	4,7
24/2 B	20-24	84	2	2	5,2
28/2 B	24-28	92	2	2	5,7
32/2 B	28-32	101	2	2	8,6
36/2 B	32-36	109	2	2	9,3
40/2 B	36-40	117	2	2	9,9
44/2 B	40-44	127	4	2	13,2
48/2 B	44-48	135	4	2	13,9
52/2 B	48-52	144	4	2	14,8
56/2 B	52-56	152	4	2	15,6

accessories optional:

- B 3** profile rail, not perforated, 28x12 mm (catalogue Cable trays)
- B 6** profile rail, not perforated, 28x15 mm (catalogue Cable trays)

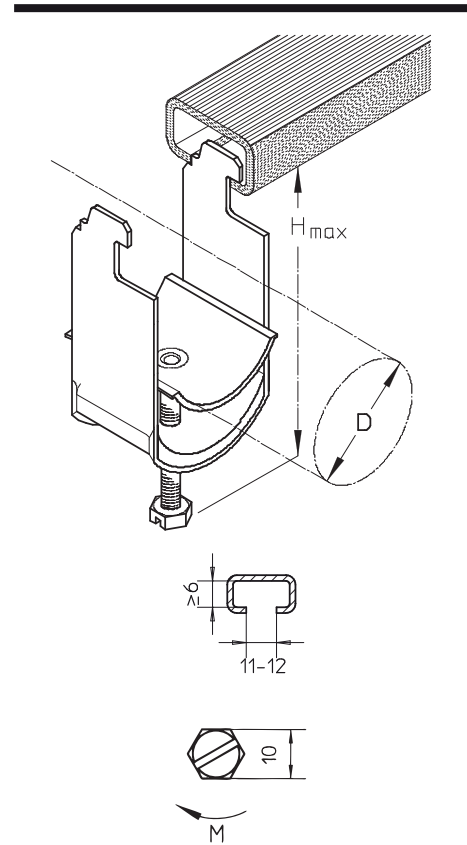

Cable clamps

HB Cable clamp for fastening to profile rails

article number	D mm	H _{max} mm	M Nm	number of cables	G kg/100
Z					
12 HB	8-12	41	2,0	1	2,5
16 HB	12-16	46	2,0	1	2,8
20 HB	16-20	50	2,0	1	3,2
24 HB	20-24	54	2,0	1	3,8
28 HB	24-28	58	2,0	1	4,1
32 HB	28-32	63	2,0	1	5,8
36 HB	32-36	67	2,0	1	6,7
40 HB	36-40	71	2,0	1	7,4
44 HB	40-44	81	4,0	1	9,3
48 HB	44-48	85	4,0	1	9,8
52 HB	48-52	90	4,0	1	10,4
56 HB	52-56	94	4,0	1	11,1
60 HB	56-60	98	4,0	1	14,7
64 HB	60-64	102	4,0	1	15,4
70 HB	64-70	109	4,0	1	17,1
12/2 HB	8-12	58	2,0	2	3,2
16/2 HB	12-16	67	2,0	2	3,9
20/2 HB	16-20	75	2,0	2	4,4
24/2 HB	20-24	84	2,0	2	5,1
28/2 HB	24-28	92	2,0	2	5,7
32/2 HB	28-32	101	2,0	2	8,7
36/2 HB	32-36	109	2,0	2	9,8
40/2 HB	36-40	117	2,0	2	10,5
44/2 HB	40-44	127	4,0	2	12,9
48/2 HB	44-48	135	4,0	2	13,5
52/2 HB	48-52	144	4,0	2	13,7
56/2 HB	52-56	152	4,0	2	16,1
AL					
12 HB-AL	8-12	41	1,5	1	1,7
16 HB-AL	12-16	46	1,5	1	1,9
20 HB-AL	16-20	50	1,5	1	2,5
24 HB-AL	20-24	54	1,5	1	2,9
28 HB-AL	24-28	58	1,5	1	3,2
32 HB-AL	28-32	63	1,5	1	4,2
36 HB-AL	32-36	67	1,5	1	4,5
40 HB-AL	36-40	71	1,5	1	4,8
44 HB-AL	40-44	81	3,0	1	6,4
48 HB-AL	44-48	85	3,0	1	7,0
52 HB-AL	48-52	90	3,0	1	9,8
56 HB-AL	52-56	94	3,0	1	10,4

accessories optional:

- B 3** profile rail, not perforated, 28x12 mm (catalogue Cable trays)
B 6 profile rail, not perforated, 28x15 mm (catalogue Cable trays)

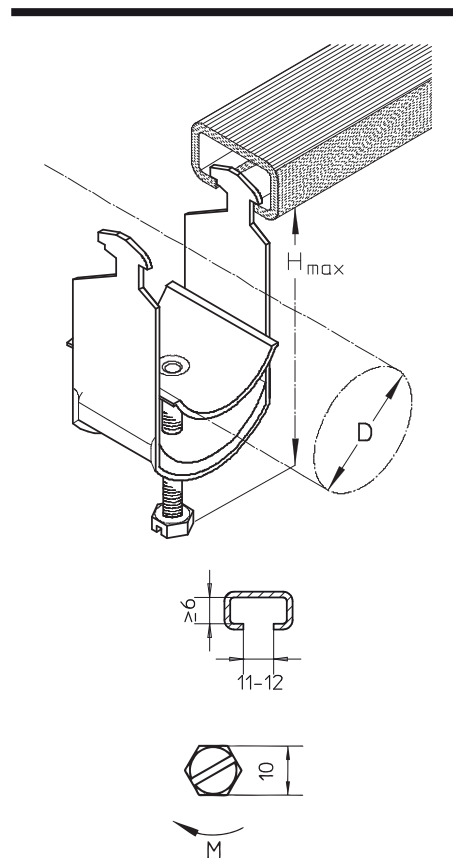

A

Cable clamps

HB-IW Cable clamp with additional insulating vat

article number	D mm	H _{max} mm	M Nm	number of cables	G kg/100
Z					
12 HB-IW	8-12	42,5	2	1	2,7
16 HB-IW	12-16	47,5	2	1	3,0
20 HB-IW	16-20	51,5	2	1	3,4
24 HB-IW	20-24	55,7	2	1	4,0
28 HB-IW	24-28	59,7	2	1	4,5
32 HB-IW	28-32	65,0	2	1	6,2
36 HB-IW	32-36	69,0	2	1	7,1
40 HB-IW	36-40	73,0	2	1	7,9
44 HB-IW	40-44	83,0	4	1	9,9
48 HB-IW	44-48	87,0	4	1	10,1
52 HB-IW	48-52	92,5	4	1	11,1
56 HB-IW	52-56	96,5	4	1	11,7
60 HB-IW	56-60	100,5	4	1	15,4
64 HB-IW	60-64	104,5	4	1	16,1
70 HB-IW	64-70	111,5	4	1	17,8

accessories optional:

- B 3** profile rail, not perforated, 28x12 mm (catalogue Cable trays)
- B 6** profile rail, not perforated, 28x15 mm (catalogue Cable trays)

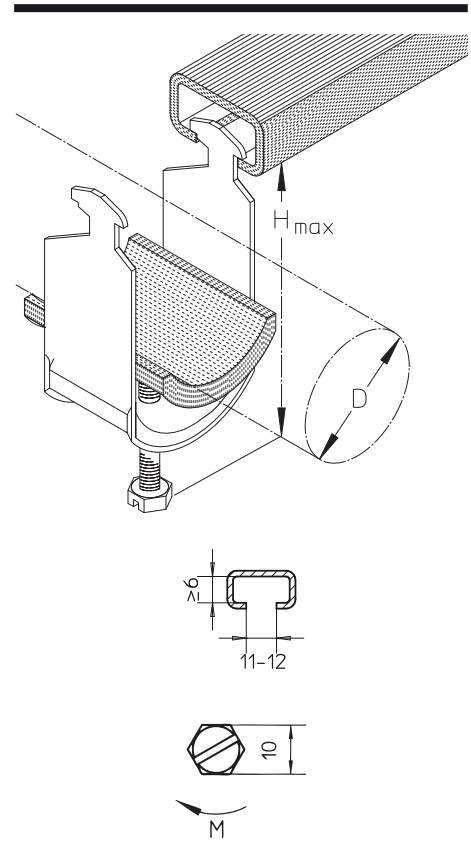

Cable clamps

ACF-E Cable clamp for fastening to C-profiles

article number	D mm	H _{max} mm	M Nm	number of cables	G kg/100
E					
12 ACF-E	8-12	41	2	1	2,4
16 ACF-E	12-16	46	2	1	2,8
20 ACF-E	16-20	50	2	1	3,1
24 ACF-E	20-24	54	2	1	3,5
28 ACF-E	24-28	58	2	1	3,9
32 ACF-E	28-32	63	2	1	4,9
36 ACF-E	32-36	67	2	1	5,8
40 ACF-E	36-40	71	2	1	6,5
44 ACF-E	40-44	81	4	1	7,4
48 ACF-E	44-48	85	4	1	8,9
52 ACF-E	48-52	90	4	1	9,9
56 ACF-E	52-56	94	4	1	10,2
12/2 ACF-E	8-12	58	2	2	3,1
16/2 ACF-E	12-16	67	2	2	3,7
20/2 ACF-E	16-20	75	2	2	4,2
24/2 ACF-E	20-24	84	2	2	4,8
28/2 ACF-E	24-28	92	2	2	5,5
32/2 ACF-E	28-32	101	2	2	7,3
36/2 ACF-E	32-36	109	2	2	8,1
40/2 ACF-E	36-40	117	2	2	9,4
44/2 ACF-E	40-44	127	4	2	11,7
48/2 ACF-E	44-48	135	4	2	12,8
52/2 ACF-E	48-52	144	4	2	13,8
56/2 ACF-E	52-56	152	4	2	15,4

accessories optional:

B 3	profile rail, not perforated, 28x12 mm	(catalogue Cable trays)
B 6	profile rail, not perforated, 28x15 mm	(catalogue Cable trays)
A 41	C-rail, not perforated, 41x41 mm	(catalogue Cable trays)
A 2	C-rail, not perforated, 50x31 mm	(catalogue Cable trays)
A 4	C-rail, not perforated, 48x26 mm	(catalogue Cable trays)
A 9	C-rail, not perforated, 40x25 mm	(catalogue Cable trays)
A 8	C-rail, not perforated, 40x22 mm	(catalogue Cable trays)
A 7	C-rail, not perforated, 40x22 mm	(catalogue Cable trays)

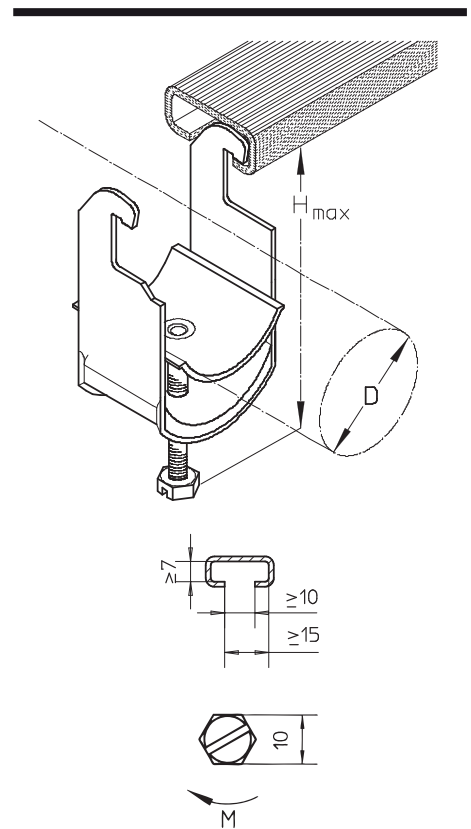

Cable clamps

S Cable clamp for fastening to angle profiles

Articles with a diameter of 12-56mm are also available in stainless steel finish, material No. 1.4571 / 1.4404 (V4A).

article number	D mm	H _{max} mm	M Nm	number of cables	G kg/100
Z					
12 S	8-12	41	2,0	1	3,6
16 S	12-16	46	2,0	1	4,1
20 S	16-20	50	2,0	1	4,6
24 S	20-24	54	2,0	1	4,8
28 S	24-28	58	2,0	1	5,3
32 S	28-32	63	2,0	1	7,9
36 S	32-36	67	2,0	1	8,4
40 S	36-40	71	2,0	1	9,0
44 S	40-44	81	4,0	1	11,2
48 S	44-48	85	4,0	1	11,7
52 S	48-52	90	4,0	1	12,4
56 S	52-56	94	4,0	1	12,9
60 S	56-60	98	4,0	1	17,2
64 S	60-64	102	4,0	1	17,7
70 S	64-70	109	4,0	1	18,6
76 S	70-76	113	4,0	1	25,3
82 S	76-82	119	4,0	1	28,5
88 S	82-88	125	4,0	1	29,4
94 S	88-94	131	4,0	1	33,2
100 S	94-100	137	4,0	1	34,8
110 S	100-110	157	4,0	1	38,2
120 S	110-120	167	4,0	1	40,3
150 S	145-150	203	6,0	1	107,7
175 S	170-175	228	6,0	1	128,0
12/2 S	8-12	58	2,0	2	4,2
16/2 S	12-16	67	2,0	2	4,9
20/2 S	16-20	75	2,0	2	5,7
24/2 S	20-24	84	2,0	2	6,2
28/2 S	24-28	92	2,0	2	6,7
32/2 S	28-32	101	2,0	2	10,3
36/2 S	32-36	109	2,0	2	11,3
40/2 S	36-40	117	2,0	2	12,0
44/2 S	40-44	127	4,0	2	15,2
48/2 S	44-48	135	4,0	2	16,6
52/2 S	48-52	144	4,0	2	16,9
56/2 S	52-56	152	4,0	2	18,2
12/3 S	8-12	71	2,0	3	5,2
16/3 S	12-16	85	2,0	3	5,9
20/3 S	16-20	97	2,0	3	6,6
24/3 S	20-24	110	2,0	3	7,5
28/3 S	24-28	122	2,0	3	8,4

E					
12 S-E	8-12	41	2,0	1	3,5
16 S-E	12-16	46	2,0	1	3,8
20 S-E	16-20	50	2,0	1	4,2
24 S-E	20-24	54	2,0	1	4,6
28 S-E	24-28	58	2,0	1	5,0
32 S-E	28-32	63	2,0	1	6,6
36 S-E	32-36	67	2,0	1	7,5
40 S-E	36-40	71	2,0	1	8,4
44 S-E	40-44	81	4,0	1	9,6
48 S-E	44-48	85	4,0	1	10,5
52 S-E	48-52	90	4,0	1	11,5
56 S-E	52-56	94	4,0	1	12,2

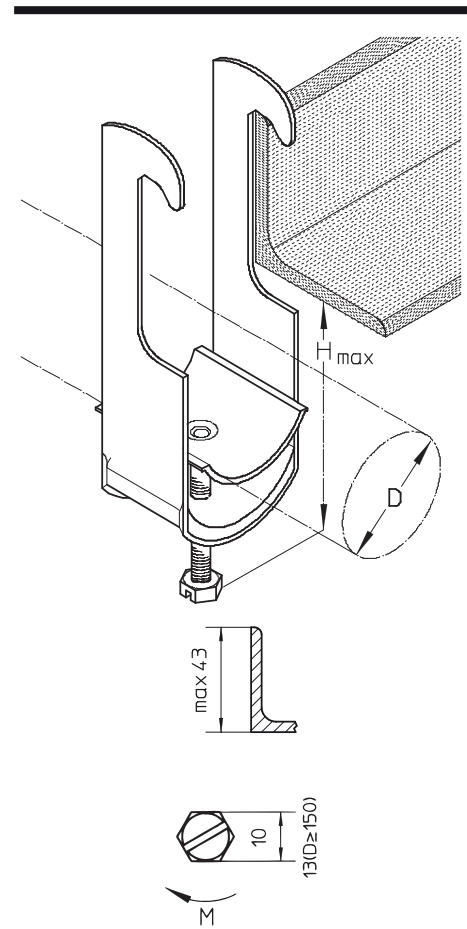

Cable clamps

S Cable clamp for fastening to angle profiles

Articles with a diameter of 12-56mm are also available in stainless steel finish, material No. 1.4571 / 1.4404 (V4A).

article number	D mm	H _{max} mm	M Nm	number of cables	G kg/100
AL					
12 S-AL	8-12	41	1,5	1	2,2
16 S-AL	12-16	46	1,5	1	2,6
20 S-AL	16-20	50	1,5	1	3,2
24 S-AL	20-24	54	1,5	1	3,6
28 S-AL	24-28	58	1,5	1	3,9
32 S-AL	28-32	63	1,5	1	5,5
36 S-AL	32-36	67	1,5	1	6,3
40 S-AL	36-40	71	1,5	1	6,9
44 S-AL	40-44	81	3,0	1	7,5
48 S-AL	44-48	85	3,0	1	8,1
52 S-AL	48-52	90	3,0	1	10,4
56 S-AL	52-56	94	3,0	1	11,2

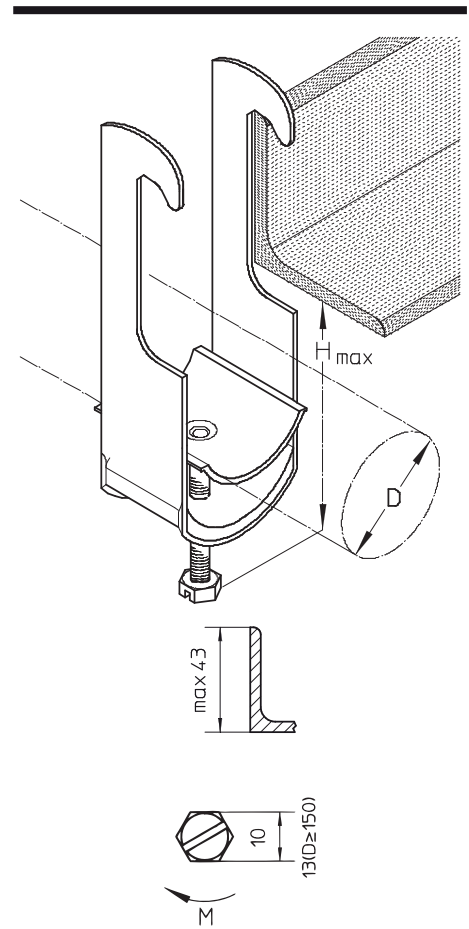

Cable clamps

S-IW Cable clamp with additional insulating vat

article number	D mm	H _{max} mm	M Nm	number of cables	G kg/100
Z					
12 S-IW	8-12	42,5	2	1	3,8
16 S-IW	12-16	47,5	2	1	4,3
20 S-IW	16-20	51,5	2	1	4,8
24 S-IW	20-24	55,7	2	1	5,1
28 S-IW	24-28	59,7	2	1	5,5
32 S-IW	28-32	65,0	2	1	8,3
36 S-IW	32-36	69,0	2	1	8,9
40 S-IW	36-40	73,0	2	1	9,3
44 S-IW	40-44	83,0	4	1	11,8
48 S-IW	44-48	87,0	4	1	12,4
52 S-IW	48-52	92,5	4	1	13,3
56 S-IW	52-56	96,5	4	1	14,0
60 S-IW	56-60	100,5	4	1	18,4
64 S-IW	60-64	104,5	4	1	19,1
70 S-IW	64-70	111,5	4	1	20,2

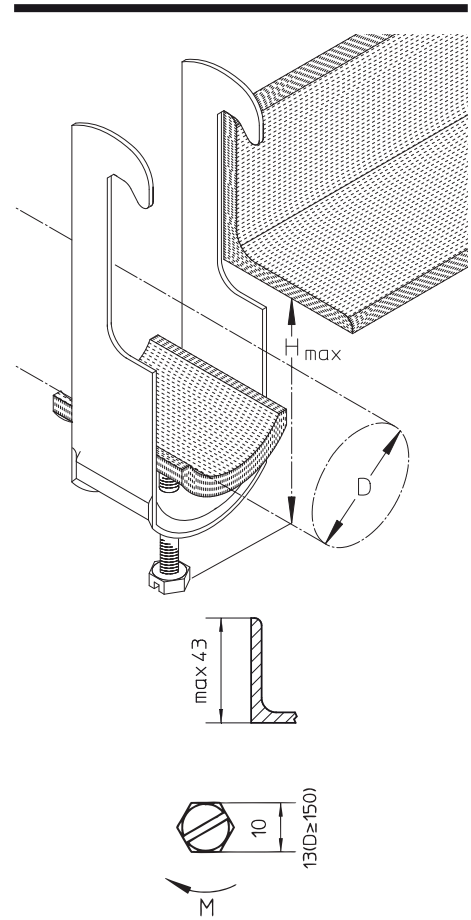

Cable clamps

U Cable clamp for fastening to flat sections

article number	D mm	H _{max} mm	M Nm	number of cables	G kg/100
Z					
12 U	8-12	41	2,0	1	3,1
16 U	12-16	46	2,0	1	3,4
20 U	16-20	50	2,0	1	3,8
24 U	20-24	54	2,0	1	4,3
28 U	24-28	58	2,0	1	4,5
32 U	28-32	63	2,0	1	7,1
36 U	32-36	67	2,0	1	7,5
40 U	36-40	71	2,0	1	8,1
44 U	40-44	81	4,0	1	10,5
48 U	44-48	85	4,0	1	10,8
52 U	48-52	90	4,0	1	11,5
56 U	52-56	94	4,0	1	12,2
60 U	56-60	98	4,0	1	16,8
64 U	60-64	102	4,0	1	17,4
70 U	64-70	109	4,0	1	18,5
76 U	70-76	113	4,0	1	24,8
82 U	76-82	119	4,0	1	27,2
88 U	82-88	125	4,0	1	28,3
94 U	88-94	131	4,0	1	31,0
100 U	94-100	137	4,0	1	33,6
110 U	100-110	157	4,0	1	35,6
120 U	110-120	167	4,0	1	38,4
150 U	145-150	203	6,0	1	108,2
175 U	170-175	228	6,0	1	133,1
12/2 U	8-12	58	2,0	2	3,9
16/2 U	12-16	67	2,0	2	4,4
20/2 U	16-20	75	2,0	2	5,0
24/2 U	20-24	84	2,0	2	5,7
28/2 U	24-28	92	2,0	2	6,1
32/2 U	28-32	101	2,0	2	9,7
36/2 U	32-36	109	2,0	2	10,6
40/2 U	36-40	117	2,0	2	11,5
44/2 U	40-44	127	4,0	2	13,4
48/2 U	44-48	135	4,0	2	14,9
52/2 U	48-52	144	4,0	2	15,8
56/2 U	52-56	152	4,0	2	17,0
12/3 U	8-12	71	2,0	3	4,5
16/3 U	12-16	85	2,0	3	5,4
20/3 U	16-20	97	2,0	3	6,2
24/3 U	20-24	110	2,0	3	7,1
28/3 U	24-28	122	2,0	3	7,9
E					
12 U-E	8-12	41	2,0	1	2,9
16 U-E	12-16	46	2,0	1	3,3
20 U-E	16-20	50	2,0	1	3,7
24 U-E	20-24	54	2,0	1	4,0
28 U-E	24-28	58	2,0	1	4,4
32 U-E	28-32	63	2,0	1	5,4
36 U-E	32-36	67	2,0	1	6,7
40 U-E	36-40	71	2,0	1	7,6
44 U-E	40-44	81	4,0	1	9,3
48 U-E	44-48	85	4,0	1	9,9
52 U-E	48-52	90	4,0	1	11,0
56 U-E	52-56	94	4,0	1	11,3

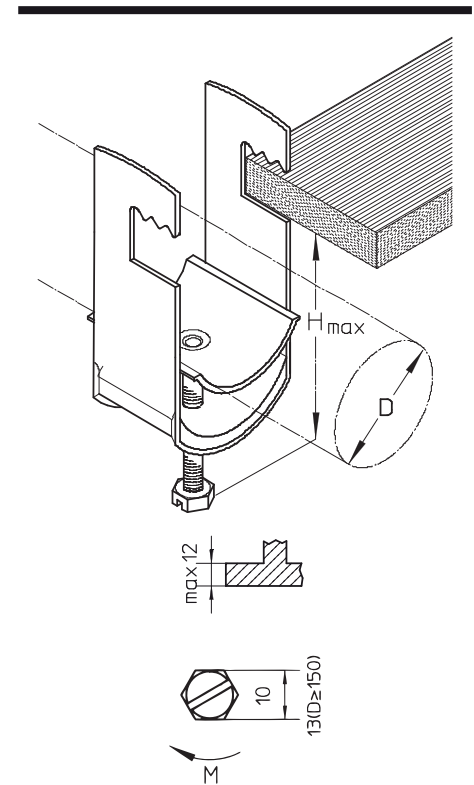

Cable clamps

U Cable clamp for fastening to flat sections

article number	D mm	H _{max} mm	M Nm	number of cables	G kg/100
AL					
12 U-AL	8-12	41	1,5	1	2,0
16 U-AL	12-16	46	1,5	1	2,6
20 U-AL	16-20	50	1,5	1	3,0
24 U-AL	20-24	54	1,5	1	3,1
28 U-AL	24-28	58	1,5	1	3,4
32 U-AL	28-32	63	1,5	1	4,5
36 U-AL	32-36	67	1,5	1	4,9
40 U-AL	36-40	71	1,5	1	5,3
44 U-AL	40-44	81	3,0	1	6,0
48 U-AL	44-48	85	3,0	1	6,4
52 U-AL	48-52	90	3,0	1	9,9
56 U-AL	52-56	94	3,0	1	10,7

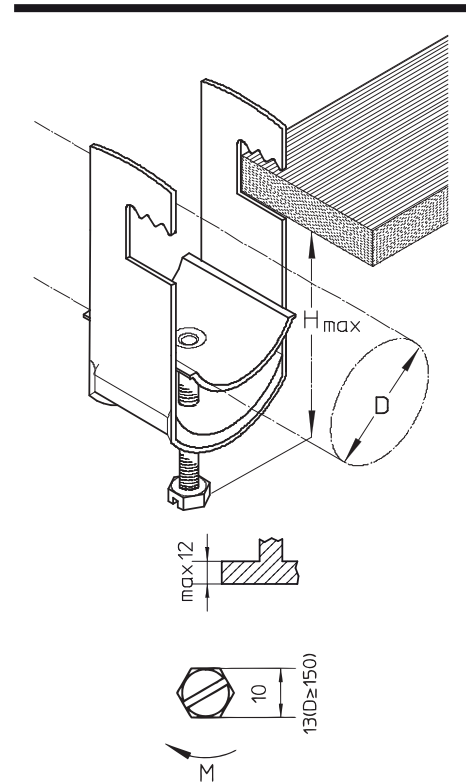

U-IW Cable clamp with additional insulating vat

article number	D mm	H _{max} mm	M Nm	number of cables	G kg/100
Z					
12 U-IW	8-12	42,5	2	1	3,3
16 U-IW	12-16	47,5	2	1	3,6
20 U-IW	16-20	51,5	2	1	4,1
24 U-IW	20-24	55,7	2	1	4,6
28 U-IW	24-28	59,7	2	1	4,8
32 U-IW	28-32	65,0	2	1	7,5
36 U-IW	32-36	69,0	2	1	7,9
40 U-IW	36-40	73,0	2	1	8,7
44 U-IW	40-44	83,0	4	1	11,1
48 U-IW	44-48	87,0	4	1	11,7
52 U-IW	48-52	92,5	4	1	12,6
56 U-IW	52-56	96,5	4	1	13,2
60 U-IW	56-60	100,5	4	1	17,5
64 U-IW	60-64	104,5	4	1	18,3
70 U-IW	64-70	111,5	4	1	19,6

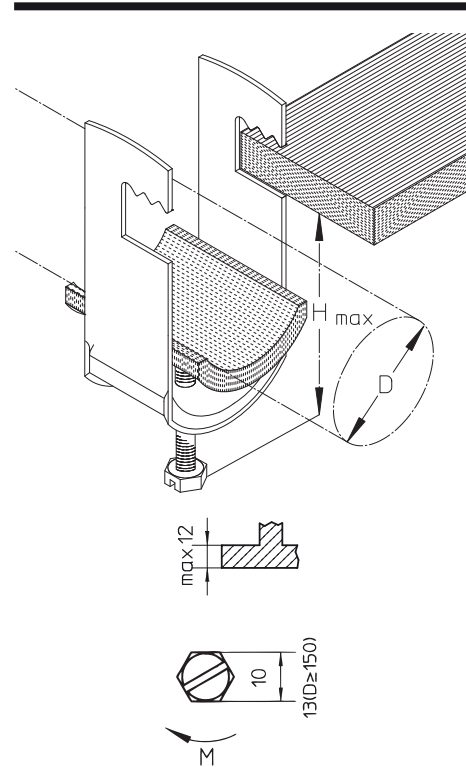

Cable clamps

RU Cable clamp for fastening to round sections

For an application example, see the chapter assembly.

article number	D mm	H _{max} mm	M Nm	number of cables	G kg/100
Z					
14 RU	8-14	48	2	1	4,3
20 RU	14-20	54	2	1	4,9
26 RU	20-26	60	2	1	5,9
32 RU	26-32	67	2	1	9,2
38 RU	32-38	74	2	1	10,5
44 RU	38-44	82	4	1	12,0
52 RU	44-52	91	4	1	14,3
60 RU	52-60	99	4	1	16,4
70 RU	64-70	109	4	1	18,4
14/2 RU	8-14	63	2	2	5,6
20/2 RU	14-20	75	2	2	6,8
26/2 RU	20-26	88	2	2	8,1
32/2 RU	26-32	101	2	2	12,5

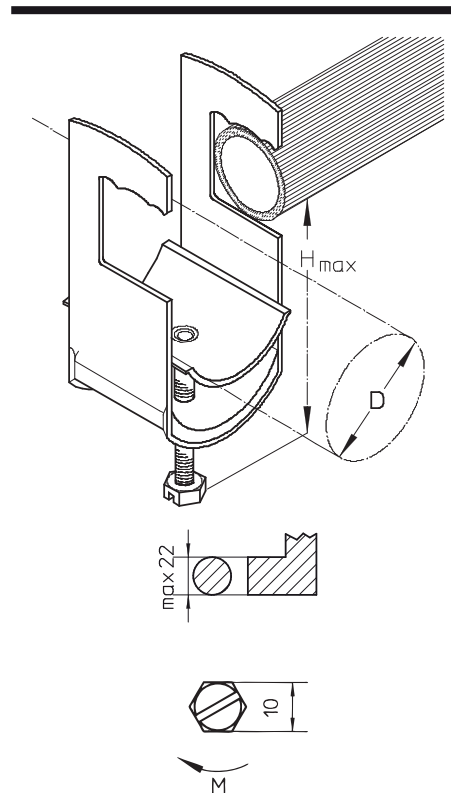

HK 30-70 cable hook

article number	D mm	H _{max} mm	number of cables	G kg/100
F				
HK 30	≤ 30	105	1	9,8
HK 40	≤ 40	110	1	11,0
HK 50	≤ 50	130	1	13,1
HK 60	≤ 60	150	1	15,1
HK 70	≤ 70	170	1	16,2

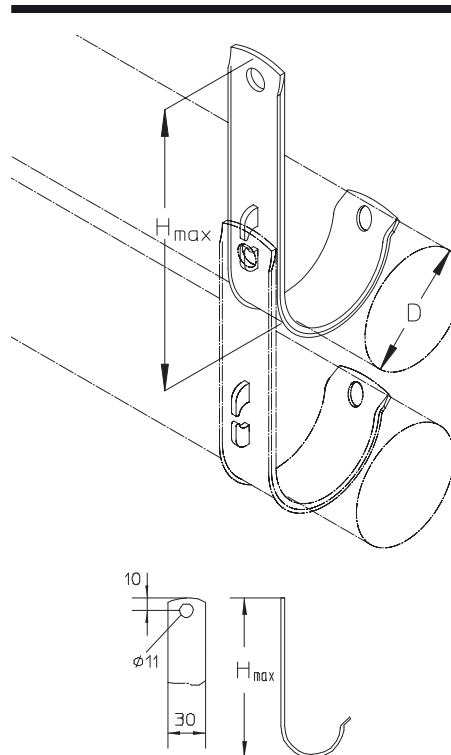

Cable clamps

HK 100 cable hook, Ø 100 mm

article number	D mm	H _{max} mm	number of cables	G kg/100
F				
HK 100	≤ 100	252	1	25,5

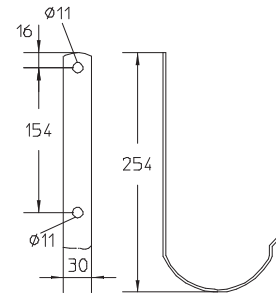
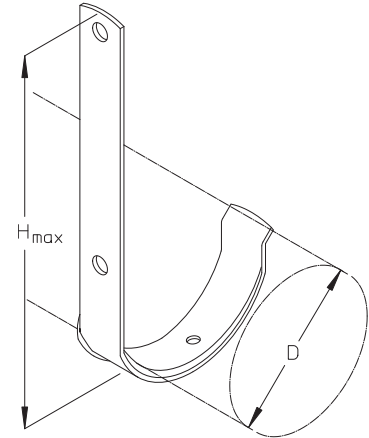

W Cable clamp for wall fastening

For an application example, see the chapter assembly.

article number	D mm	M Nm	G kg/100
Z			
16 W	12-16	2	4,4
20 W	16-20	2	5,4
24 W	20-24	2	5,8
28 W	24-28	2	6,3
32 W	28-32	4	8,5
36 W	32-36	4	9,1
44 W	36-44	4	13,5
52 W	44-52	4	16,5
60 W	52-60	4	19,5

accessories optional:

SSV countersunk head screw (page D06)

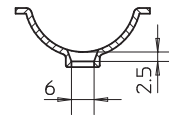
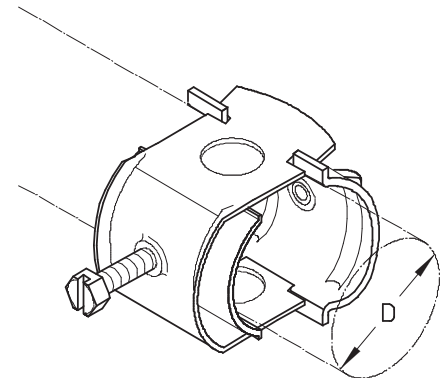

Cable clamps

KH cable support

article number	D mm	L mm	G kg/100
Z			
KH 12	≤ 12	15	4,2
KH 16	≤ 16	20	4,9
KH 20	≤ 20	20	5,2
KH 24	≤ 24	20	5,3
KH 28	≤ 28	20	5,6
KH 32	≤ 32	20	6,6

